

Thread Insert Testing Procedure

Appendix 6

7-12-06

The following is Kirby Morgan Dive Systems approved method for testing the Thread Inserts on the Kirby Morgan SuperLite-17, 17C and 27 Helmets, and KM-37 Helmet, KMB-18 Band Mask. In various manuals and written references through the years the viewing lens has been referred to as the lens, viewing lens, port and view port. All refer to the transparent lens that the diver sees through when wearing the mask or helmet. Testing of the inserts should be done at least ONCE A YEAR.

Thread Insert Testing

When testing the Thread Inserts on a helmet or mask, or when removing and replacing the port retainer, it is crucial that the KMDSI recommended torque specs be followed when tightening the Port Retainer Screws. Any over torquing of a screw can result in serious damage to either the thread insert or the surrounding fiberglass in the port area. This can lead to loosening of the Port Retainer and in extreme instances to flooding of the helmet. This testing procedure is designed to locate any inserts that have been damaged and need replacing. Any replacement/ repair of inserts and the surrounding fiberglass port area must be carried out by an authorized KMDSI trained representative that has trained specifically in thread insert repair/replacement. Any other repair/replacement is not authorized by KMDSI.

One of the main causes of insert damage is the over torquing of the Port Retainer Screws. This can be the final result of poor maintenance of the mask/helmet. Poor maintenance of the O-ring and O-ring groove on the mask/helmet can lead to leaks around the Port Retainer. Overtightening of the retainer will not solve the leak and will damage the fiberglass surrounding the inserts. Be sure that only a KMDSI Port O-ring is used for the seal under the Lexan Port. This O-ring is a specially molded soft compound and was designed specifically for this application. Other O-rings, while being approximately the same size, will not perform correctly and can cause leaks in the port area, leading to overtightening and insert damage.

Definitions:

Port Retainer: The metal frame that holds the Port in place against the sealing O-ring of the mask or helmet main body.

Face Port: The transparent Lexan port that the diver sees through.

Port Retainer Mount Screws: Screws that hold the Port Retainer to the main body of the mask/helmet.

Kirby Morgan, SuperLite, Band Mask, KMB Band Mask, EXO, SuperMask, SuperFlow, and Rex are all registered trademarks of Kirby Morgan Dive Systems, Inc. Use of these terms to describe products that are not manufactured by KMDSI is not permitted without written permission from KMDSI.

© Copyright 1970-2006 Kirby Morgan Dive Systems, Inc. All rights reserved. This manual is made available for the express use of owner of this Kirby Morgan product. No part of this manual may be reproduced, stored in any retrieval system, or transmitted, or used in any form or by any means, whether graphic, electronic, mechanical, photocopy, or otherwise by technology known or unknown, without the prior written permission of Kirby Morgan Dive Systems, Inc.

Copyright 2003-2006, Dive Lab®, Inc. All rights reserved.

Thread Inserts: The metal, female threaded, inserts that are bonded into the main body of the mask/helmet. These inserts receive the Port Retainer Mounting screws. The Port Retainer Mounting Screws hold the Port Retainer in place. The Port Retainer holds the Port in place on the main mask/helmet body.

Tools Required: Adjustable Torque Screwdriver
Insert Test Jig Block, Screw & Washer

Test Procedure:

1. Remove the Port Retainer, Port and O-Ring according to the instructions in the mask/helmet manual.
2. Place the Insert Testing Jig block over one of the screw inserts and thread the testing jig screw through the washer and hole in the jig and into the insert, tightening it hand tight (Fig. B).
3. Using the Adjustable torque screwdriver, slowly tighten the test jig screw to 14 inch pounds (12 for the KMB 28). While tightening, observe the insert and surrounding area. The insert should not move at all and there should not be any cracks in the surrounding fiberglass. Also listen for cracking sounds as you tighten the screw. Any such sounds are an indication that the fiberglass surrounding the insert has been stressed and is damaged and should be repaired.
4. With the screw tightened, check for cracks around the outside edge of the port area (Fig. B). If any are found, this area must be repaired, as this is a sign that the insert has been over tightened and has damaged the fiberglass.
5. If, after checking all the inserts, they all check out O.K., place a drop of Super Glue around each insert where the insert meets the fiberglass, this will help keep the joint sealed. Replace the port, O-ring, and Port Retainer according to the manual instructions and tighten all Port Retainer screws to 12 inch pounds with the adjustable torque screwdriver.
6. Fig. A gives the specifications for the Testing Jig. The Block is machined from aluminum stock.

Thread Insert Testing Procedure
Appendix 6
7-12-06

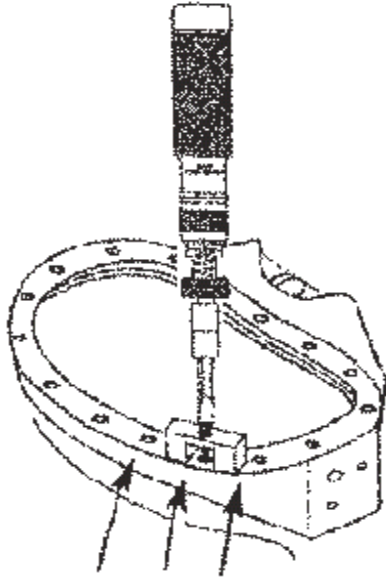

Check for cracks around the outside of the Port area around the insert.

Kirby Morgan, SuperLite, Band Mask, KMB Band Mask, EXO, SuperMask, SuperFlow, and Rex are all registered trademarks of Kirby Morgan Dive Systems, Inc. Use of these terms to describe products that are not manufactured by KMDSI is not permitted without written permission from KMDSI.

© Copyright 1970-2006 Kirby Morgan Dive Systems, Inc. All rights reserved. This manual is made available for the express use of owner of this Kirby Morgan product. No part of this manual may be reproduced, stored in any retrieval system, or transmitted, or used in any form or by any means, whether graphic, electronic, mechanical, photocopy, or otherwise by technology known or unknown, without the prior written permission of Kirby Morgan Dive Systems, Inc.

Copyright 2003-2006, Dive Lab®, Inc. All rights reserved.

Thread Insert Testing Procedure

Appendix 6

7-12-06

Insert Testing Jig

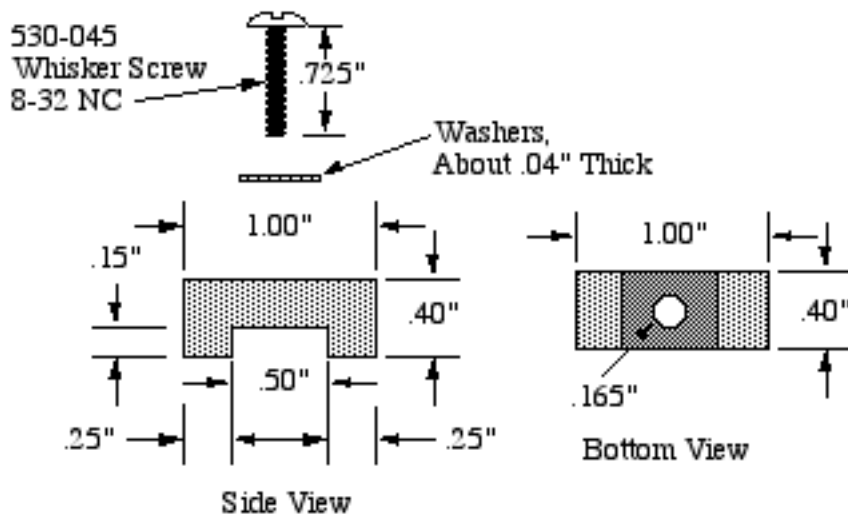

Kirby Morgan, SuperLite, Band Mask, KMB Band Mask, EXO, SuperMask, SuperFlow, and Rex are all registered trademarks of Kirby Morgan Dive Systems, Inc. Use of these terms to describe products that are not manufactured by KMDSI is not permitted without written permission from KMDSI.

© Copyright 1970-2006 Kirby Morgan Dive Systems, Inc. All rights reserved. This manual is made available for the express use of owner of this Kirby Morgan product. No part of this manual may be reproduced, stored in any retrieval system, or transmitted, or used in any form or by any means, whether graphic, electronic, mechanical, photocopy, or otherwise by technology known or unknown, without the prior written permission of Kirby Morgan Dive Systems, Inc.

Copyright 2003-2006, Dive Lab®, Inc. All rights reserved.